

PERKO® CAT. NO. 9703 BATTERY DISCONNECT SWITCH WITH ALTERNATOR FIELD DISCONNECT



INSTALLATION AND OPERATING INSTRUCTIONS

For use with alternators and generators rated 6-32 V.D.C. switch rating 480 amperes continuous, 1200 amperes intermittent (15 sec. on, 5 min. off). Locate switch to keep battery cables short as possible. All wiring to the switch shall be performed by a QUALIFIED MARINE ELECTRICIAN, and in accordance with the "Fire Protection Standard For Motor Craft," N.F.P.A.* No. 302, The standards of the American Boat and Yacht Council, Inc.* and the U.S.C.G.* safety standards for boat electrical systems (33CFR183). If the installation requires operation at the continuous rated switch capacity (480 AMPS) in engine compartments, then the minimum cable size recommended is 4/0 (200° C insulation). Other cable sizes may be required due to length of run and load, therefore consult engine manufacturer's recommendations for battery cable size and specifications for the installation.

CAUTION: Always STOP engines before switching to "OFF" position.

Erratic operation, particularly after very long periods of idleness, can be cleared by rapidly switching back and forth briskly several times without any load connected.

- NOTE:**
- (1) Locate switch to keep battery cables short as possible.
 - (2) If switch is to be mounted in an area subject to corrosion, it is recommended that a liquid electrical coating be applied to the terminal connections.
 - (3) Terminal stud size is 1/2 inch. Torque terminal nuts to 21 ft-lbs.
 - (4) Mounting screw size #10 pan head or round head. Do not over-tighten screws to prevent deforming the switch.

Alternator field disconnect is used to break the field current and protect the alternator diodes if the battery switch is inadvertently turned to the "OFF" position with the engine running. See Diagram # 2

The following diagram illustrates a typical installation.

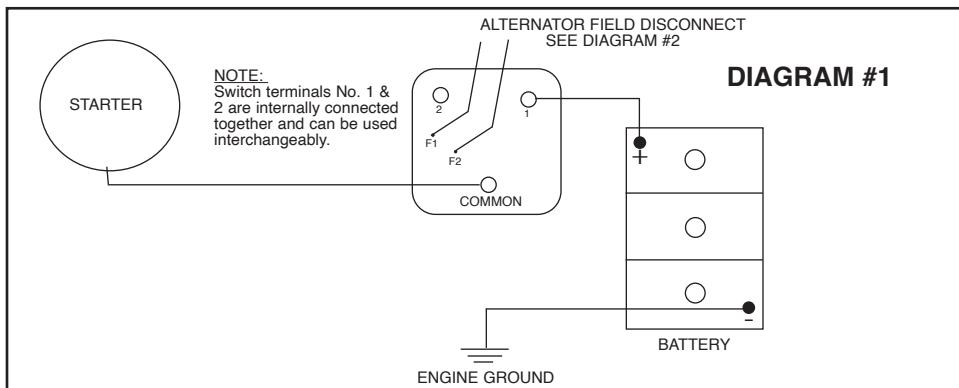
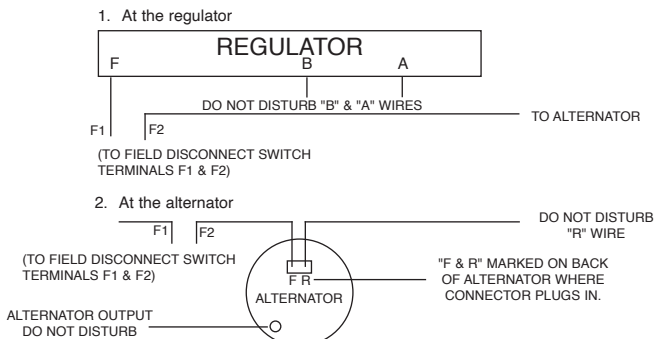

DIAGRAM #2 ALTERNATOR FIELD DISCONNECT

- A. Use minimum 14 AWG wire, suitable for marine engine compartments.
- B. On systems with a separate voltage regulator, splice the field disconnect switch into the field "F" as shown.



- C. On unitized alternators with built-in regulator - a field disconnect cannot be installed

1. American Boat & Yacht Council, Inc.
613 Third Street, Suite 10
Annapolis, MD 21403

2. U.S. Coast Guard
Washington, D.C. 20593
(or your local C.G. office)

3. N.F.P.A.
1 Batterymarch Park
Quincy, MA 02269

Perko Inc.
16490 N.W. 13th Avenue
Miami, FL 33169-5707
www.perko.com